

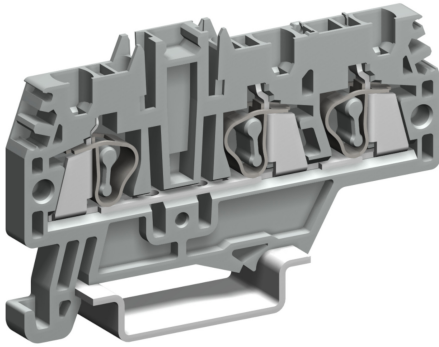

Spring-clamp terminal block 2.5mm² 1+2, 1-level, grey color



Series	HMM
Code	HM510GR
Type	HMM.2/1+2/GR
HS code	85369010
Colour	grey
TECHNICAL FEATURES	
Function/Type	Feed-through
Rated cross-section	2.5 mm ²
Connecting capacity	
Flexible wire	0.2-4 mm ²
Rigid wire	0.2-4 mm ²
Wire with ferrule - ferrule type	2.5 mm ² - WP25/14
Characteristics according to European standard IEC EN 60947-7-1-	
Maximum voltage AC/DC	800 V
Maximum current (rated cross-section)	24 A
Caliber	A3
Characteristics according to UL	
Maximum voltage AC/DC	600 V
Maximum current (rated cross-section)	20 A
Section (min-max)	24-12 (AWG)
Characteristics according to ATEX directive and IEC ex standard	
Maximum voltage AC/DC	500 V
Maximum current (rated cross-section)	24 A
Service temperature Min/Max	-40 °C / +80 °C
Rated impulse withstand voltage / pollution degree	8 kV / 3
Insulation stripping length	10 mm
Width (pitch)	5.2 mm
Length	66 mm
Height mounted on TH35-7.5/TH35-15/G32	41 / 49 / - mm
Insulation material temperature index (EN 60216-1)	130 °C
Plastic material	Polyamide UL94V-0
ACCESSORIES	
End section	
Grey	HMT.2/1+2/PT/GR (cod. HM511GR)
Blue	HMT.2/1+2/PT (Ex)i (cod. HI511)
Thickness	1.5 mm
Cross-connection	
Model A)	PTC/03/... (cod. PTC03...)
Model B)	PTP/03/... (cod. PTP03...)
Rated current carrying capacity IEC/ATEX	24 A / 24 A
Cross-connection identification strip	PTC/SP (cod. PTC0990)
Coloured partition plate	DFH/2/R (cod. DH02R)
Cross-connection barrier	-
Test plug	SDD/1 (cod. DD001)
Modular test plug	SDH/5 (cod. DH005)
End section for modular test plug	SH5/PT (cod. DH501)
Marking	
Single marking tag	CNU/8/51 (cod. NU0851S)
Single marking tag for pitch insertion	CNU/8/51 (cod. NU0851S)
End bracket	
TH35 screw type	BT/3 (cod. BT003)
TH35 snap-fit type	BTO (cod. BT007)
TH35 and G32 snap-fit type	BTU (cod. BT005)
DIN rail according to IEC 60715/TH35	PR/3/..
APPROVALS AND MARKINGS	

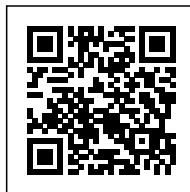

1 For more details on accessories, refer to the relevant chapters

PRODUCT DESCRIPTION

HMM.2/1+2/GR Spring-clamp terminal block 2.5mm² 1+2, 1-level, grey color